



# INLINE WAD FAN

## WARM AIR DEHUMIDIFIER FAN + EXTRACTOR

### ABOUT THE INLINE WAD BOX FAN

This is a central system ventilation unit that incorporates Warm Air Dehumidifier Inline unit



The WAD INLINE unit ensures a supply air and extract air system that will intake & extract.

The dual box fan provides for multiple ventilation options from mounted positions in the: attic, utility cupboard, bathroom, kitchen (not directly above cooker), underfloor or basement locations. Each providing a unique ventilation system meeting with building regulation requirements and most significantly a superb way of minimising air flow noise, introducing fresh pre-warmed air, when the temperature is below 14°C, and maximising condensation control.

The WAD INLINE FAN is a fully automated fan, with dual actions of both intake and extraction of air, with the benefit of warming the fresh external air when it is drawn into the building, or filtered air from the attic space. The unit is completely automatic and operating for your maximum benefit and air condition with internal humidity control, external air temperature sensor, light switch or remote timed overrun. This unit works best when used as part of a cross-flow ventilation system with other Vapourflow units.

The WAD INLINE FAN system is a twin brushless inline fan with the advantage of 120mm air flow system, the controls offer two switched live inputs with proportional timers, operates with continuous to high speed or simple off to high (or low) speed with the switched live inputs.

### FEATURES AND BENEFITS

- For best results use the WAD Inline as part of a cross-flow ventilation system with other Vapourflow units
- Ventilation system is compact and quiet
- Bolts together with Inline Box Fan to make dual compact system
- Fully automatic Warm Air Dehumidifier that benefits your home throughout
- Warmed and dry fresh air creates better “quality of life” in your home
- The 200 watt heater only works when the external temperature is below 14°C and is not required when the fan is in extract mode
- Incorporates the Autostat Humidity Controller which continually monitors ambient humidity and automatically adjusts the control level accordingly
- Low energy, low running cost long life fan
- Low high speed manual switch, with bluetooth, speed control via app
- Stainless steel housing
- Produces up to 150m<sup>3</sup>/h of airflow
- Manual override extract option via light switch or switch live
- WAD Kit includes Filter Sock, 1.5m Semiregid ducting & Inlet grille - white round, ducting Jubalee Ring
- 5 year motor guarantee, 2 year product guarantee



# SPECIFICATIONS

## INPUT

Input Voltage	220-240V 50Hz
Fan Input Power (trickle)	10.5W
Fan Input Power (boost)	10.5W
Heater	200W
Earth Leakage	>1M $\Omega$

## PERFORMANCE

Air Flow (intake)	80m <sup>3</sup> /hr max
Air Flow (extract)	150m <sup>3</sup> /hr max
Static Pressure intake	75 Pa
Static Pressure extract	150Pa
Acoustic Noise	Input 34 dB(A) Extract 30 dB(A)
Life Expectancy	>50,000 hours
Specific Fan Power	0.2 W/(l/s)

## GENERAL

Operating Temperature	-10° to +60°C
Storage Temperature	-15° to +40°C
Weight	4.5kg
RoHS Compliance	Yes
Optional extras: Kits: Remote Autostat Inline Kit. WAD Kit	
Size	17cm x 17cm x 23cm, 12cm $\varnothing$

## MECHANICAL

Housing Material	Stainless Steel
Impact Strength	390 J/m (ASTM D790)
Flammability	N/A
Flame Retardant	Foam: BS 476 Pt7 Class 1
Heat Distortion	Foam 120°C

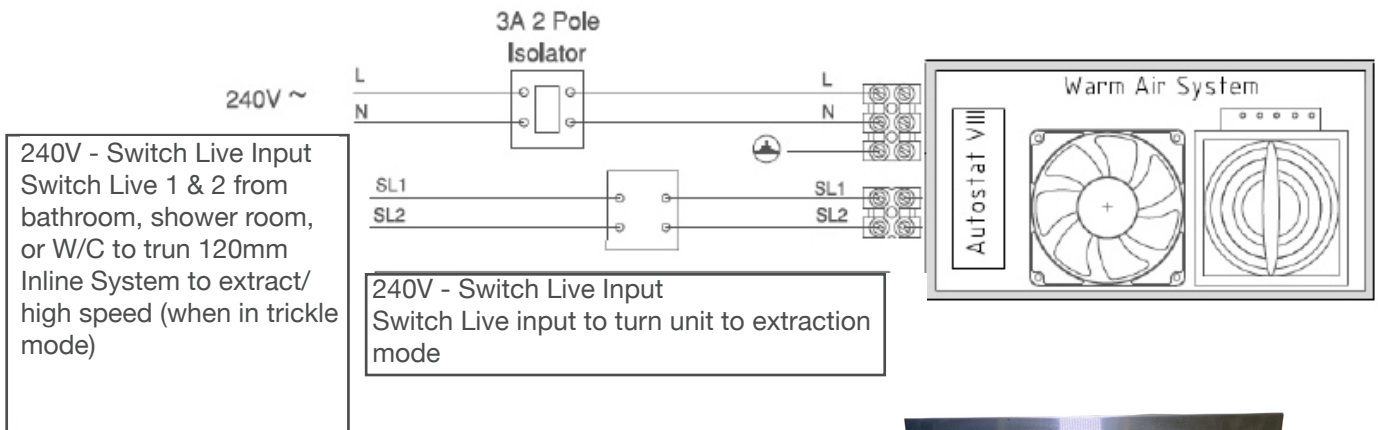

## PART NUMBERS

### 2. Inline WAD

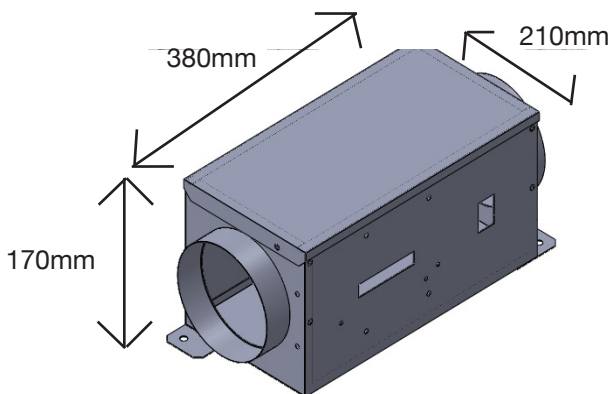

Download the **VAPOURFLOW** app here:



# VapourFlow

VapourFlow Limited  
 Henley Buisness Centre  
 Newtown Road  
 RG9 1HG  
 United Kingdom  
 01491 410170  
 vapourflow.com  
 vents@vapourflow.com